



US007558082B2

(12) **United States Patent**
Jitaru

(10) **Patent No.:** **US 7,558,082 B2**
(45) **Date of Patent:** **Jul. 7, 2009**

(54) **METHOD AND APPARATUS FOR CONTROLLING A SYNCHRONOUS RECTIFIER**

(75) Inventor: **Ionel D. Jitaru**, Tucson, AZ (US)

(73) Assignee: **DET International Holding Limited**, Grand Cayman (KY)

(*) Notice: Subject to any disclaimer, the term of this patent is extended or adjusted under 35 U.S.C. 154(b) by 176 days.

(21) Appl. No.: **10/509,983**

(22) PCT Filed: **Mar. 28, 2003**

(86) PCT No.: **PCT/CH03/00203**

§ 371 (c)(1),
(2), (4) Date: **Apr. 21, 2005**

(87) PCT Pub. No.: **WO03/084037**

PCT Pub. Date: **Oct. 9, 2003**

(65) **Prior Publication Data**

US 2005/0254266 A1 Nov. 17, 2005

Related U.S. Application Data

(60) Provisional application No. 60/368,508, filed on Mar. 29, 2002.

(51) **Int. Cl.**
H02M 3/335 (2006.01)

(52) **U.S. Cl.** **363/21.06; 363/21.08; 363/21.14**

(58) **Field of Classification Search** **363/21.06, 363/21.08, 21.14, 21.16, 98, 131, 17, 89**

See application file for complete search history.

(56) **References Cited**

U.S. PATENT DOCUMENTS

5,179,512	A	1/1993	Fisher et al.	
5,757,627	A *	5/1998	Faulk	363/21.14
5,991,171	A	11/1999	Cheng	
6,594,161	B2 *	7/2003	Jansen et al.	363/21.14

FOREIGN PATENT DOCUMENTS

EP	1 150 417	10/2001	
WO	PCT/US00/27897	4/2001	

* cited by examiner

Primary Examiner—Shawn Riley

(74) *Attorney, Agent, or Firm*—Gallagher & Kennedy, P.A.; Thomas D. MacBlain

(57) **ABSTRACT**

The present invention is directed to a switch mode power converter for supplying an output power to a load, which includes a switching device having a switching input, a switching output, and a control input for enabling or disabling the switching device from conducting current from the switching input to the switching output. The converter also includes a network in which the switching device input, the switching device output, and the load are connected together to form a circuit. The converter also includes a bias winding in the circuit for producing a bias voltage representative of the output power, and a control circuit. The control circuit is for (a) determining the rate of change of the bias voltage, (b) characterizing the rate of change, and (c) controlling the control input as a result of the characterization (b).

38 Claims, 14 Drawing Sheets

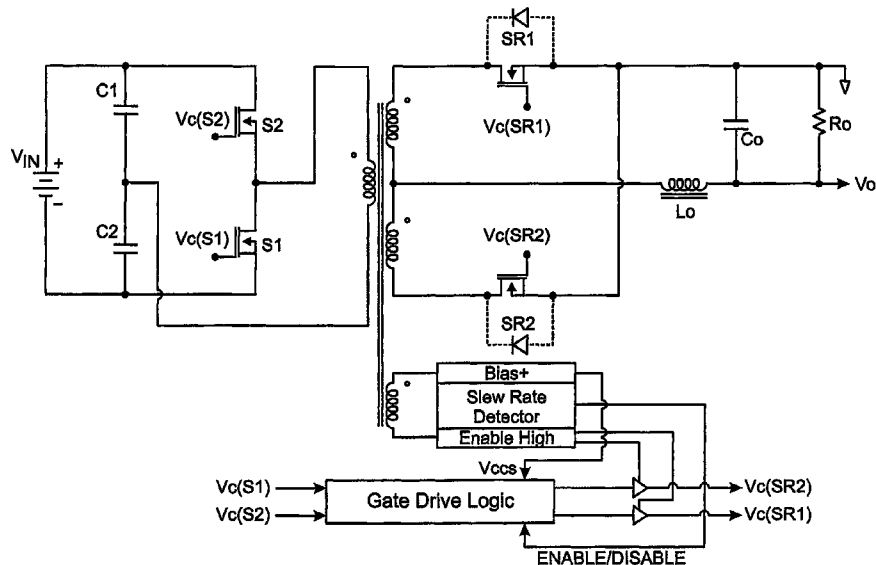

Fig. 1
(PRIOR ART)

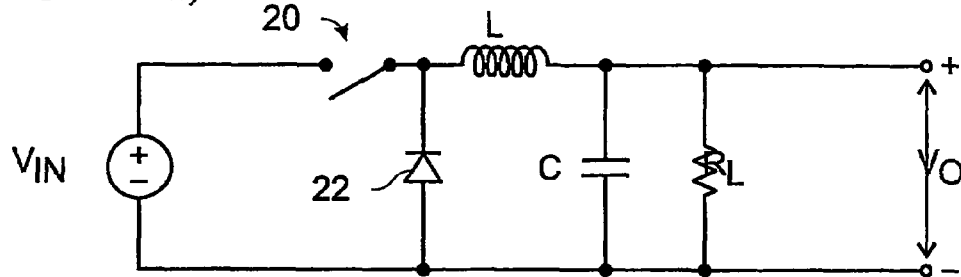

Fig. 2
(PRIOR ART)

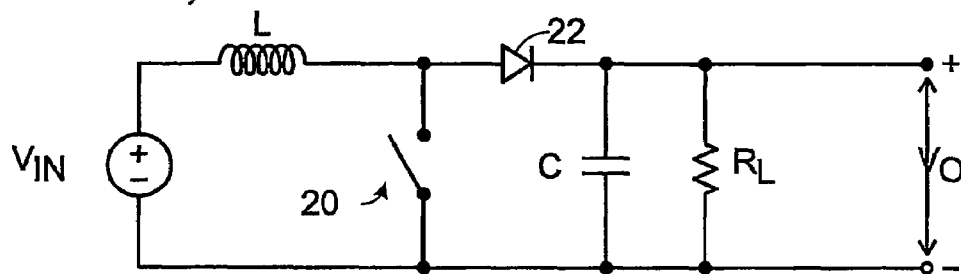

Fig. 3
(PRIOR ART)

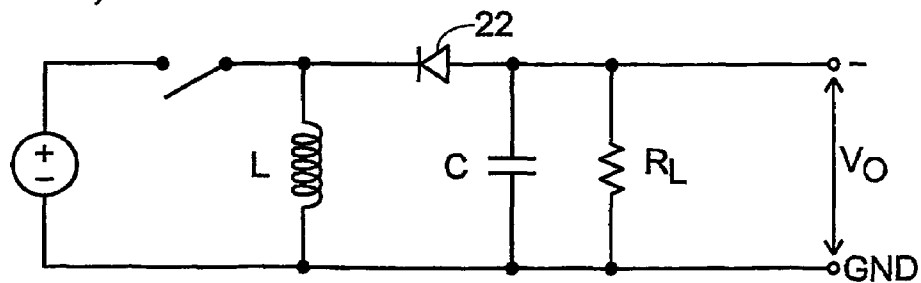

Fig. 4a
(PRIOR ART)

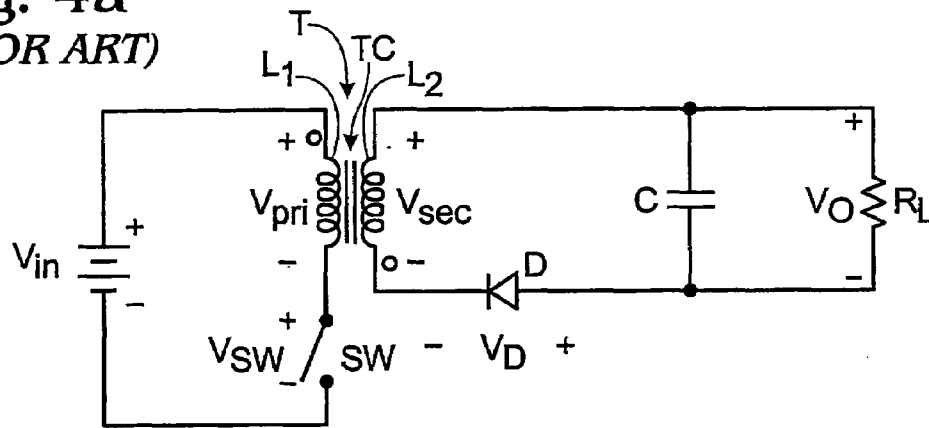

Fig. 4b
(PRIOR ART)

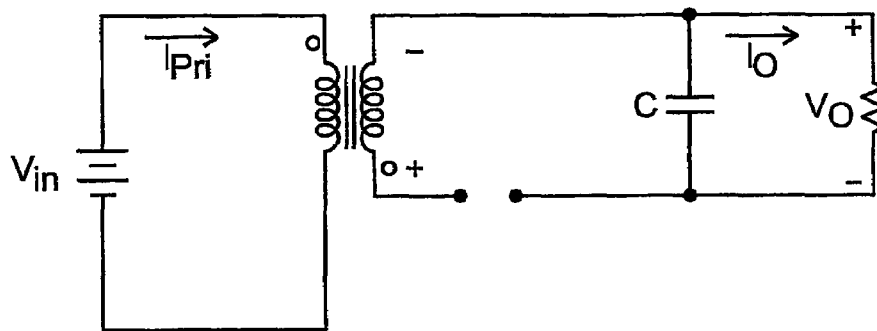
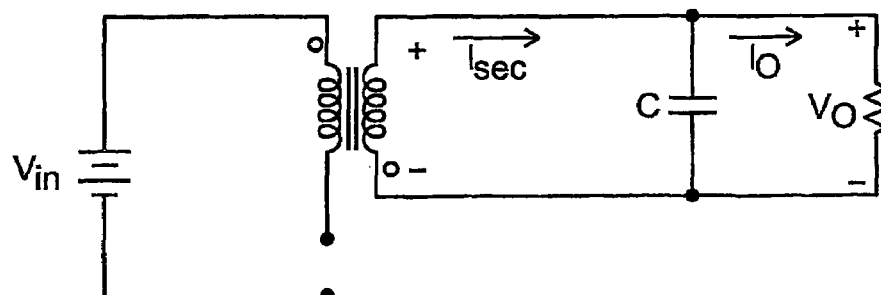
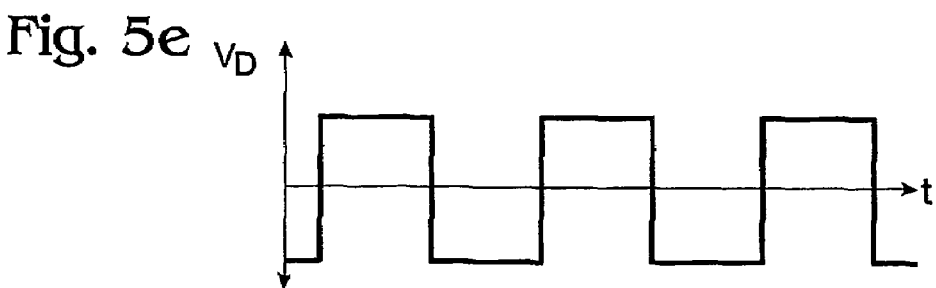
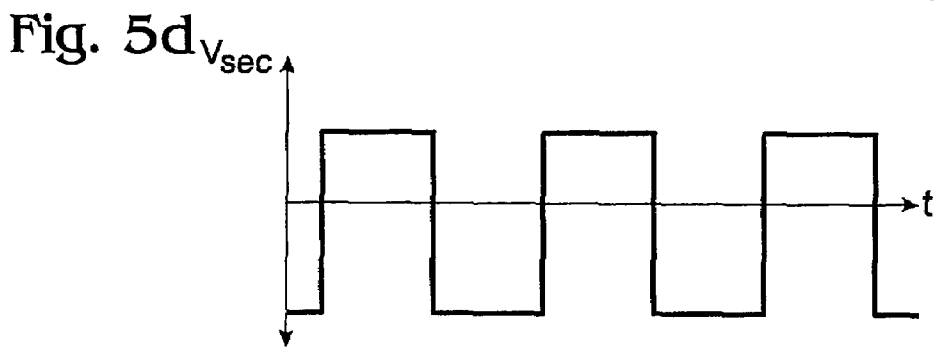
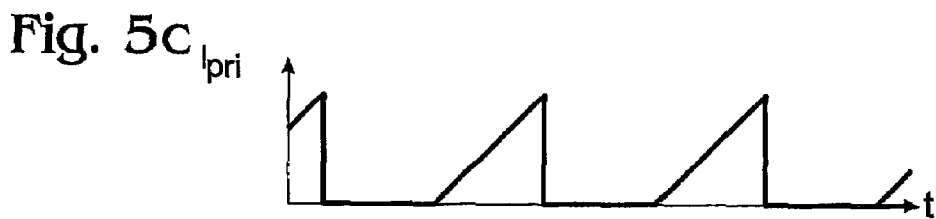
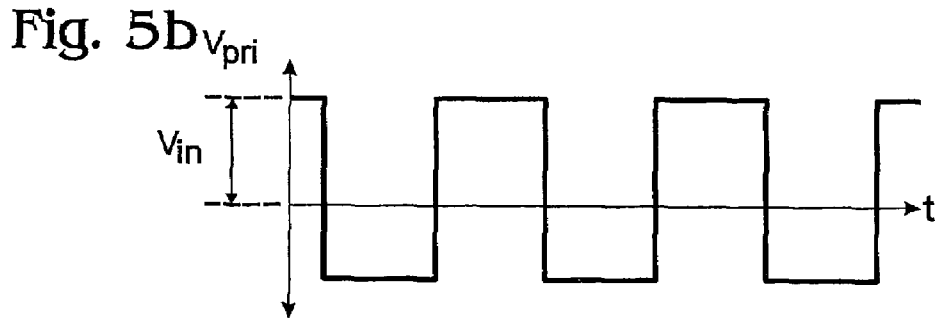
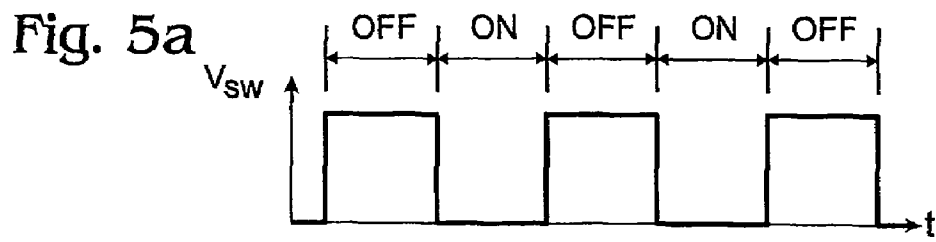

Fig. 4c
(PRIOR ART)





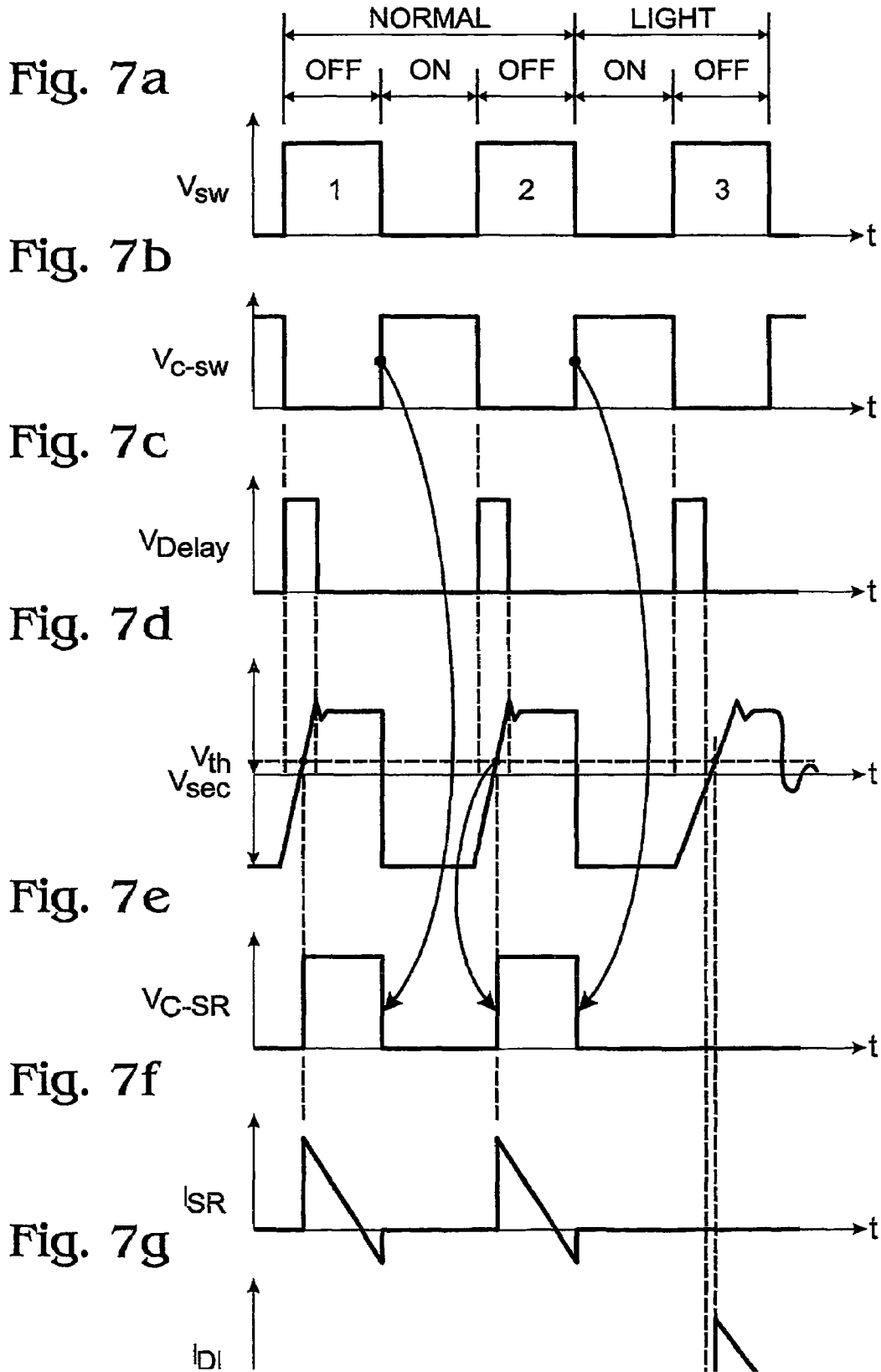

Fig. 8

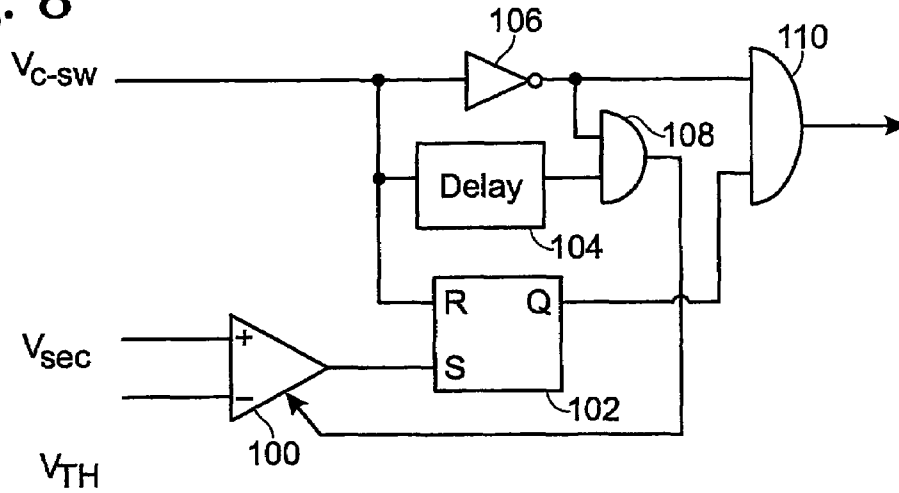
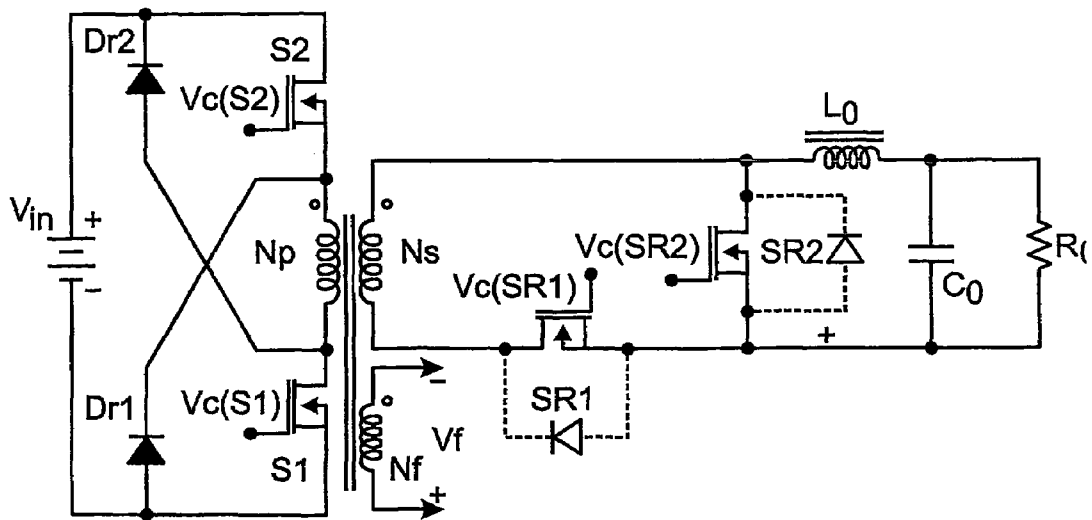

Fig. 10a



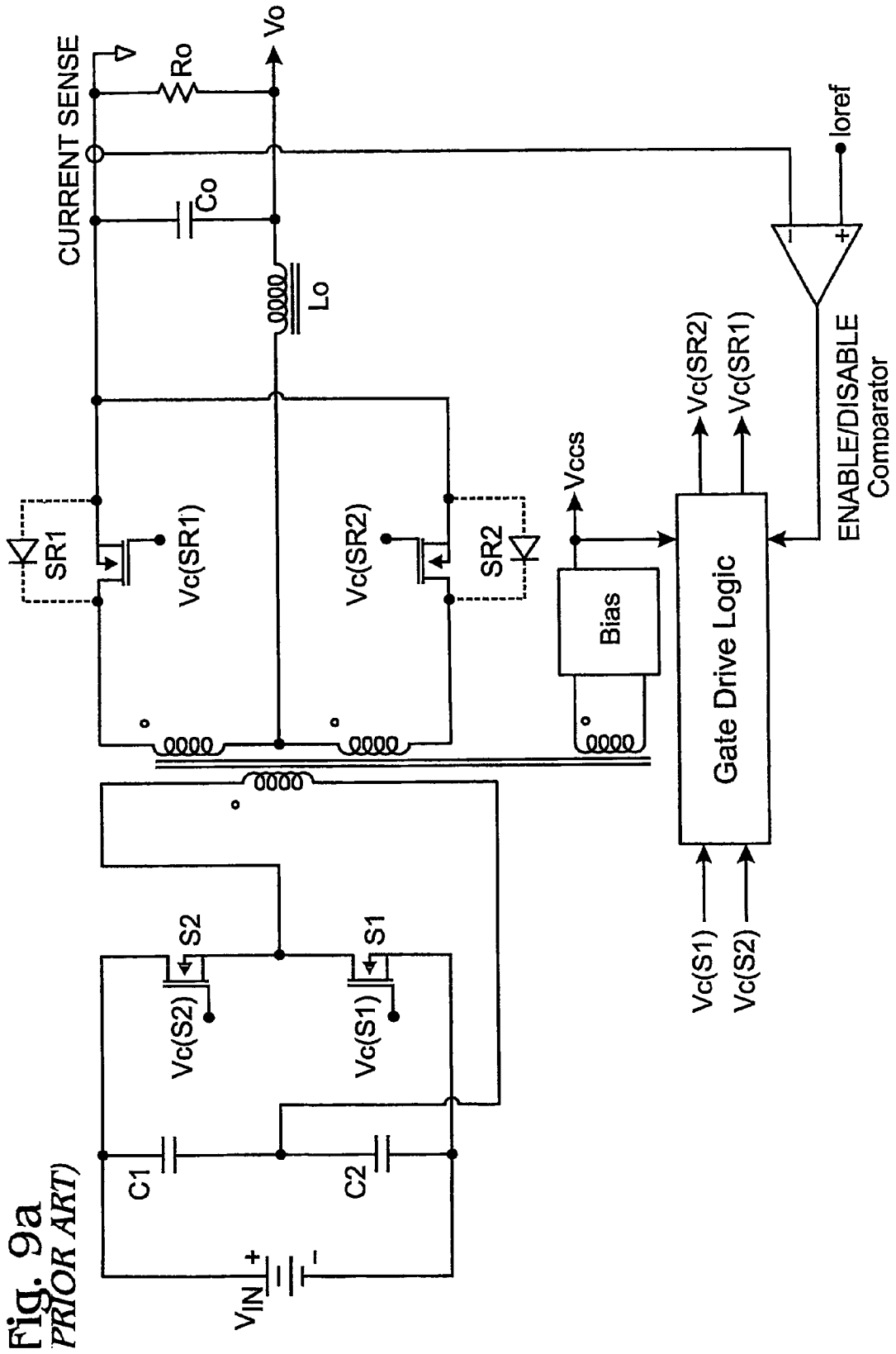

Fig. 9a
PRIOR ART

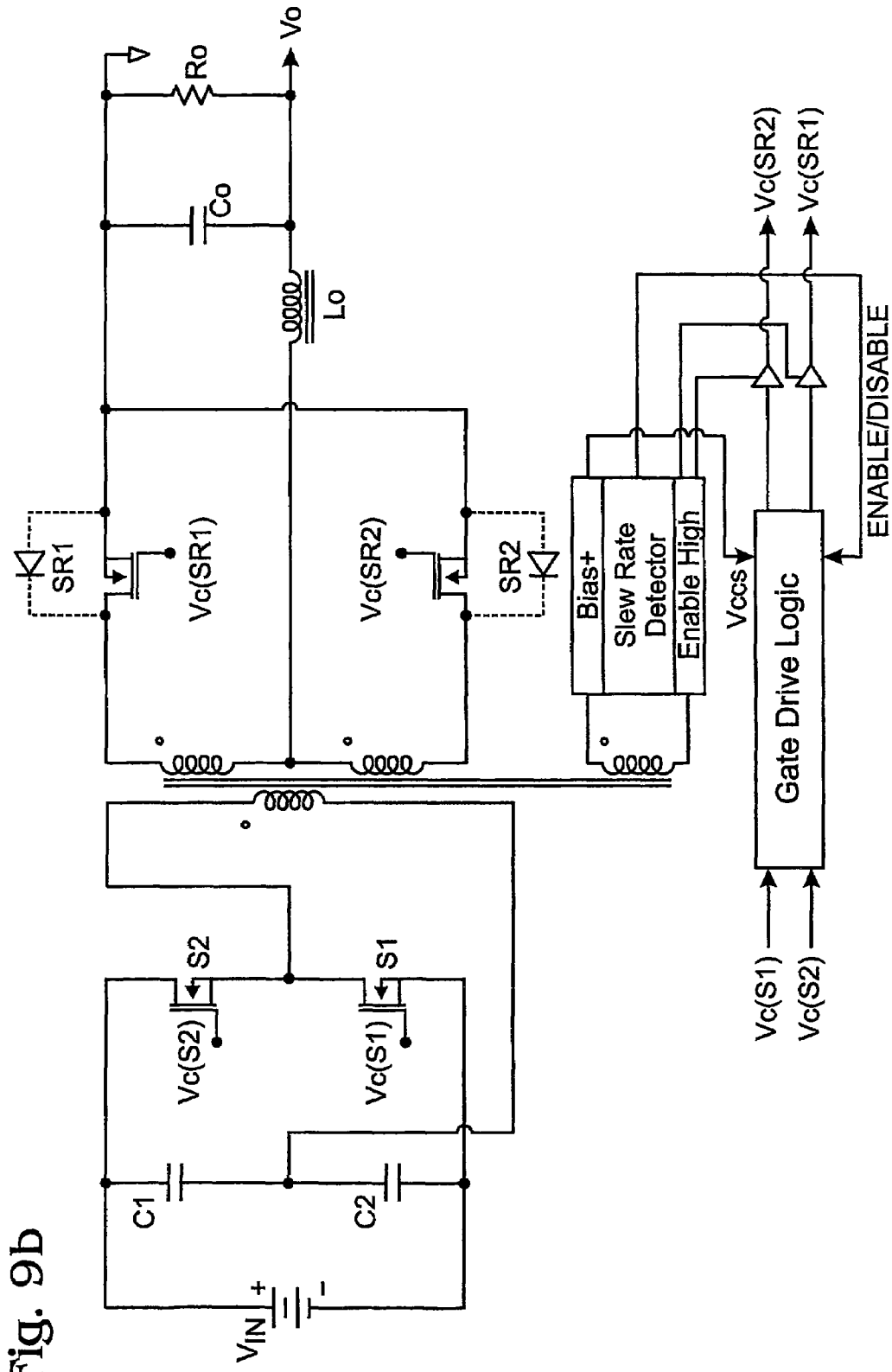

Fig. 9b

Fig. 10c

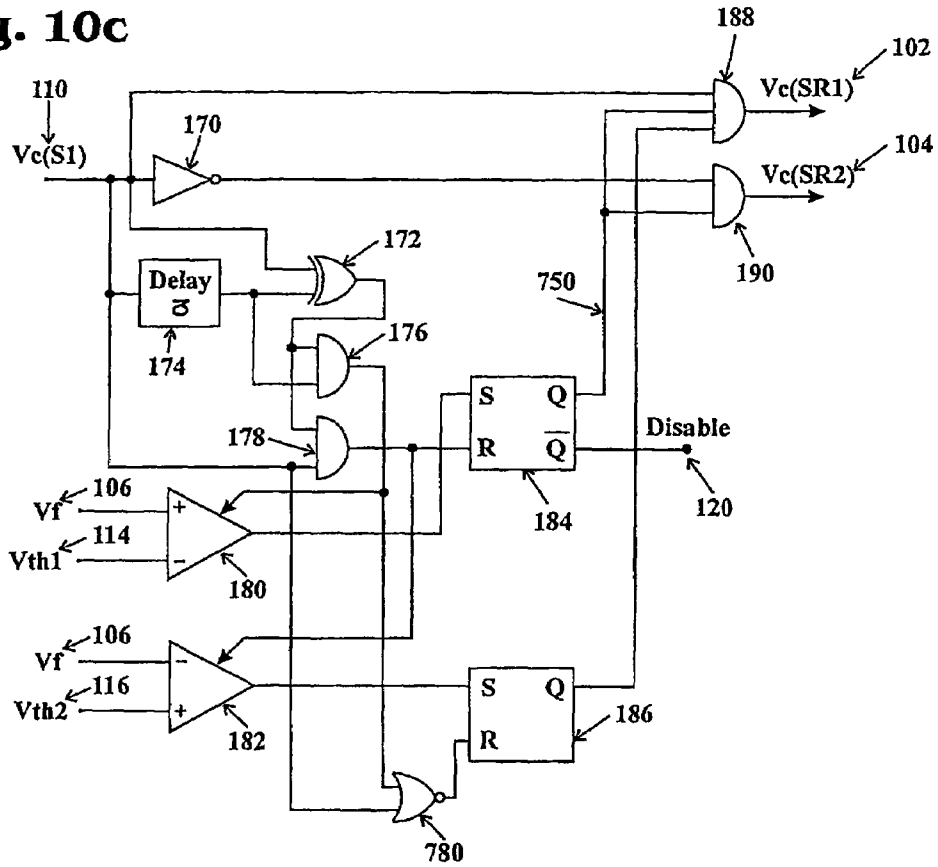
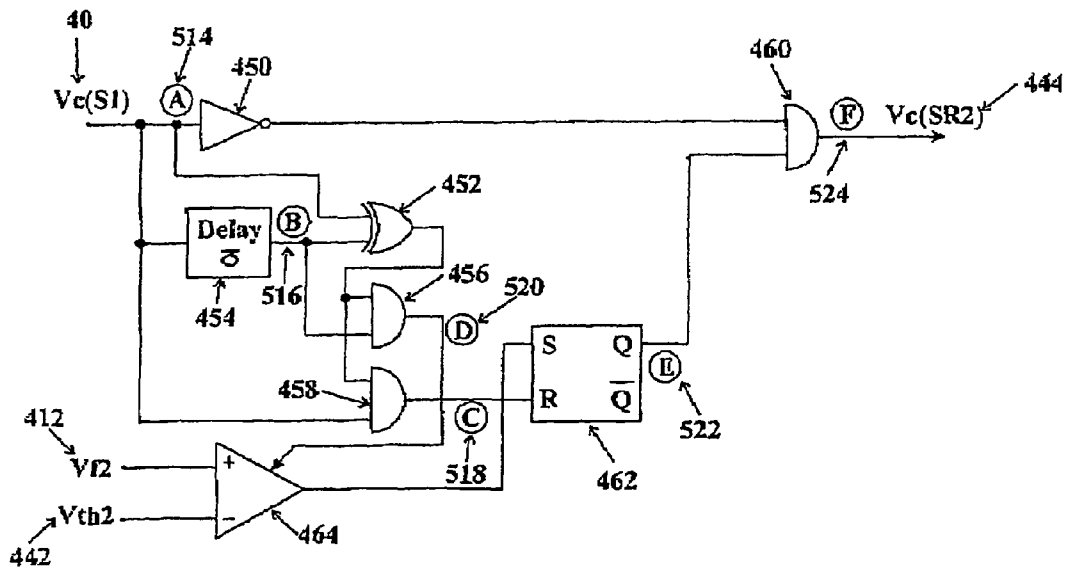

Fig. 12c



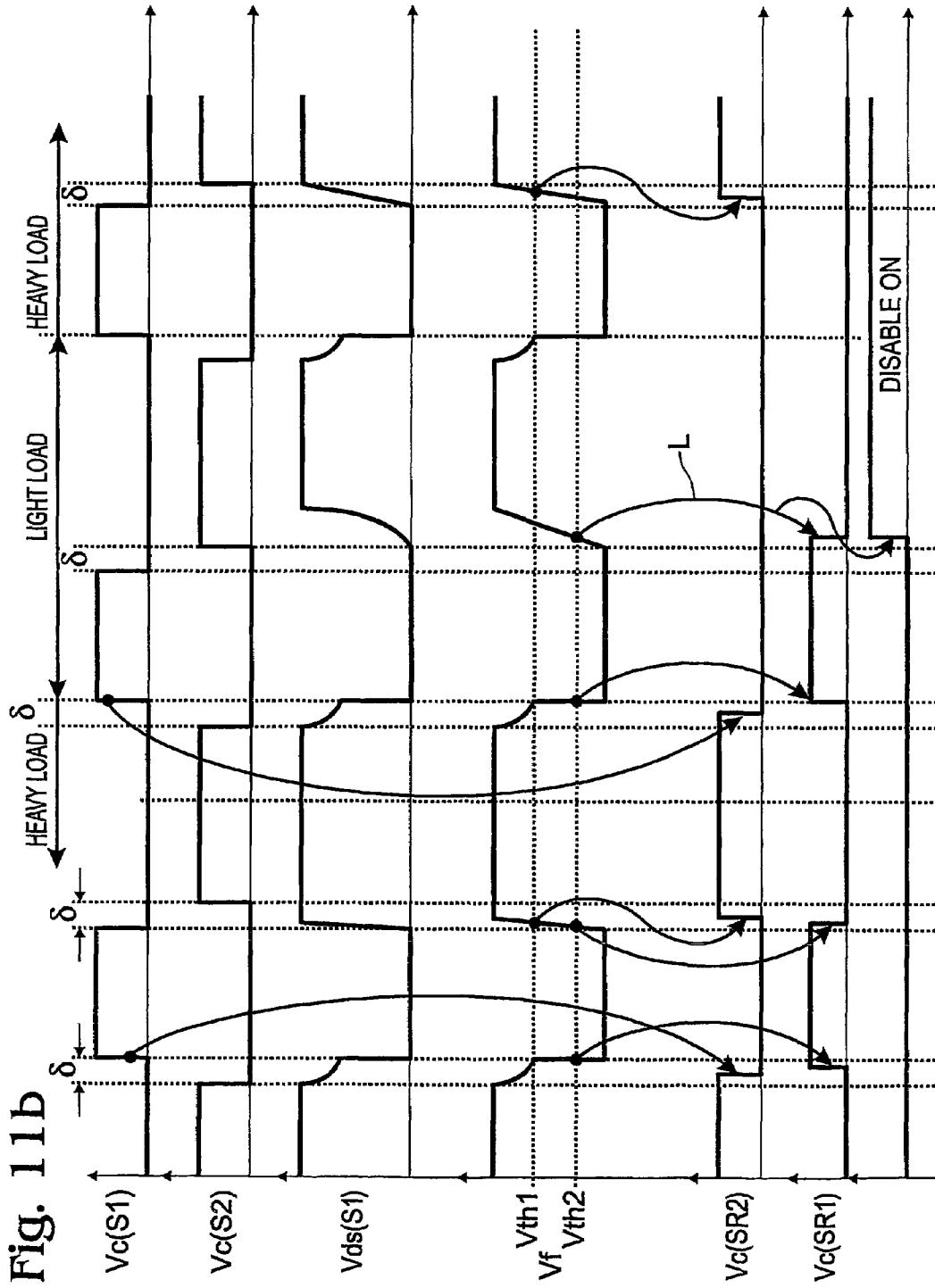

Fig. 11b

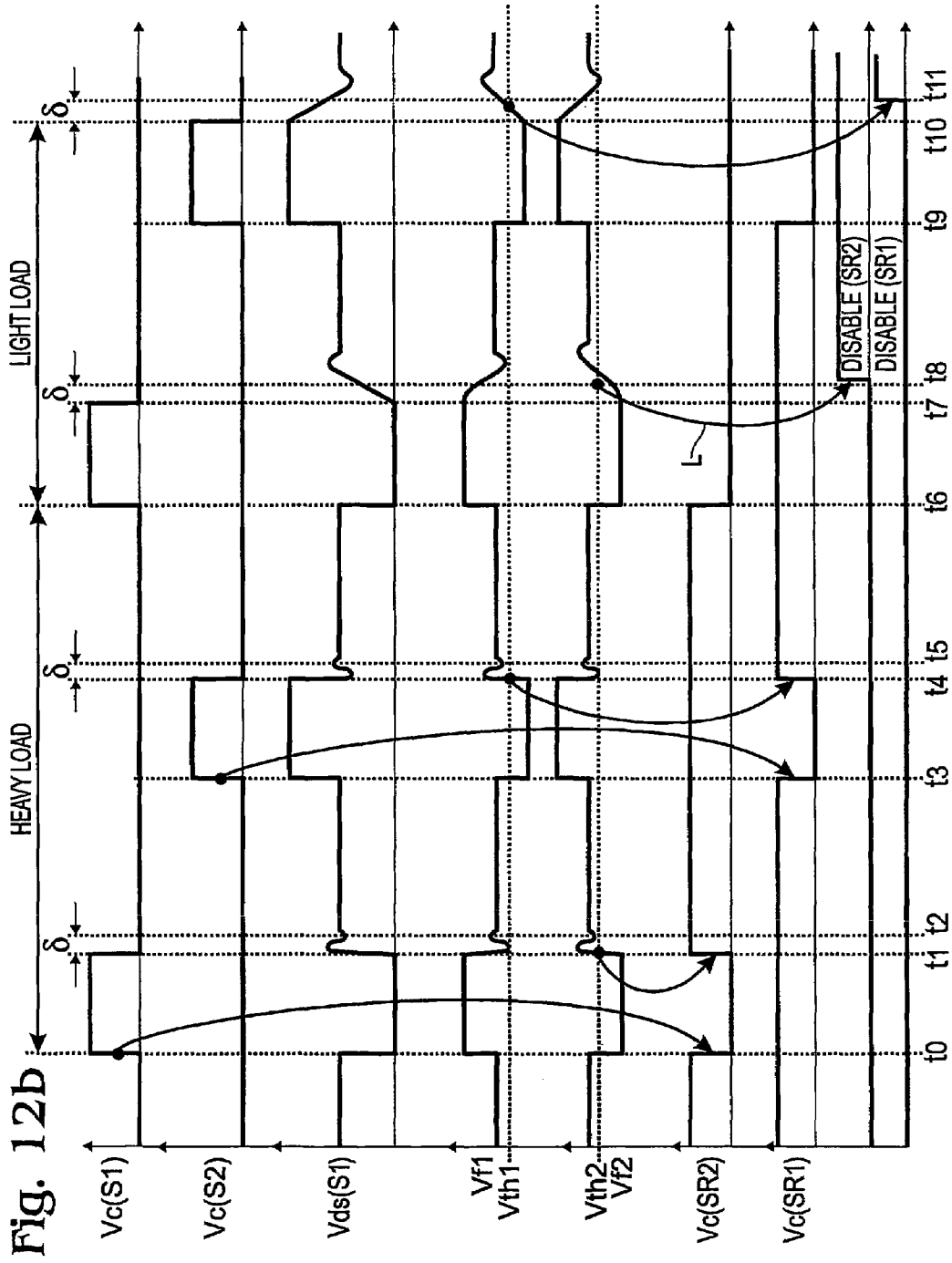

Fig. 12b

METHOD AND APPARATUS FOR CONTROLLING A SYNCHRONOUS RECTIFIER

This application claims the benefit of the provisional appli- 5
cation Ser. No. 60/368,508 filed on 29 Mar. 2002 and entitled
Driving Synchronous Rectifiers, which is incorporated by
reference in its entirety. This application is the U.S. national
stage of international application PCT/CH03/00203, filed
Mar. 28, 2003. 10

BACKGROUND

The present invention is directed generally to the field of 15
power electronics, and specifically to a method and apparatus
for controlling a synchronous rectifier.

BACKGROUND

In order for any electric circuit or device (a "load") that 20
runs on electricity to operate properly, electric power must be
supplied to it; and this power must be supplied at levels of
current and voltage, and within tolerances, that are specified
for a particular load. A switched-mode power converter is a
device that receives electric energy from a raw input source
generally not suited for a load and supplies a regulated output
of electric energy in a form and an amount that is suitable for
a particular load.

A switched-mode power converter includes at least one 30
primary switch that is used to switch a direct current input on
and off to produce a time-varying voltage and current. The
direct current input may be supplied by a battery or be derived
by rectifying an alternating current. A switched-mode con-
verter includes a magnetic storage element, which may be an
inductor, and frequently is a transformer for electrically iso- 35
lating input from output. The time-varying voltage and cur-
rent is coupled to the magnetic storage element. When the DC
input is switched on, a magnetic field is induced in the mag-
netic storage element, and when the DC input is switched off,
the magnetic field collapses, transferring the stored energy 40
into an electrical current.

A switched-mode power converter also includes a circuit 45
for controlling the primary switch or switches used to switch
the input current on and off. The time period when the switch
is closed is referred to as T_{ON} or simply the "on" period and
the time period when the switch is off is referred to as T_{OFF} or
simply the "off" period. A switching time period T_S or "duty
cycle" is defined as $T_S = T_{ON} + T_{OFF}$. The control circuit can
regulate the amount of power that is delivered to the load by
making the on period longer or shorter for a fixed duty cycle. 50
Alternatively, the amount of power delivered can be regulated
by making the duty cycle longer or shorter for a fixed on
period. Because the output voltage of a switched-mode con-
verter generally depends on the input voltage, the duty cycle,
and the load current, a feedback signal indicative of the output
voltage or current is provided to the control circuit for use in
regulating the duty cycle. 55

In addition to the primary switch, a switched-mode power
converter commonly includes one or more switches that control 60
the flow of current and prevent it from flowing in certain
directions within the converter circuit. These devices for con-
trolling the flow of current in a switched-mode power con-
verter are referred to herein as "secondary switches."

Switch mode power converters in a variety of topologies 65
are known. Some of the primary topologies that use an induc-
tor as the magnetic storage element are the buck, boost, and
buck-boost topologies. The buck topology is shown in FIG. 1,

the boost topology is shown in FIG. 2, and the buck-boost
topology is shown in FIG. 3. Other important topologies that
use an inductor as the magnetic storage element are the full-
bridge, half-bridge, and Cuk topology. In FIGS. 1-3, the ref-
erence numbers 20 and 22 identify, respectively, the primary
and secondary switches. In other topologies, the primary and
secondary switches are located similarly to the locations
shown in FIGS. 1-3. In general, some of the principal switch
mode power converter topologies that incorporate a trans-
former as a magnetic storage element to achieve electrical
isolation include the flyback converter which is derived from
the buck-boost converter, the forward converter which is
derived from the buck converter, the forward-flyback con-
verter, the push-pull converter which is derived from the buck
converter, and the half-bridge and full-bridge converters
which are derived from the buck converter. The forward con-
verter, a modified version of the forward converter known as
the two-transistor forward converter, the forward-flyback
converter, and the half-bridge and the full-bridge converters
have, in addition to a transformer, one or more inductors on
the output or secondary side of the transformer dial serve as
additional magnetic storage elements.

In some topologies, energy is transferred to the magnetic
storage element (or elements) and to the load during the T_{ON}
portion of the duty cycle. This may be referred to as a forward
transfer. The transfer of energy from the magnetic storage
element to the load that occurs during the T_{OFF} portion of the
duty cycle may be referred to as the flyback transfer. If the
topology has two secondary switches and both switches con-
duct current during the flyback transfer, the topology is
referred to as a symmetrical topology. On the other hand, if
the topology has two secondary switches and one switch
conducts only during the forward transfer and other conducts
only during the flyback transfer, the topology is referred to as
an asymmetrical topology. In addition, if the topology has
only one secondary switch and the switch conducts during the
forward and flyback transfer, the topology is considered an
asymmetrical topology. Symmetrical topologies include the
full-bridge, half-bridge, and push-pull. Asymmetrical topolo-
gies include the forward converter, the two-transistor forward
converter, and the forward flyback converter with an active
clamp. In addition, to the symmetrical and asymmetrical
topologies, there is a third type of topology in which there is
only one secondary switch and it conducts only during the
flyback transfer. The flyback converter is an example of this
third type of topology.

Diodes have traditionally been used as a secondary
switch within switched-mode power converters. A diode has
input and output terminals and may be either forward- or
reverse-biased. An "ideal" diode will conduct a current when
the input terminal is at a higher voltage than the output by a
"cut-in voltage," that is, when it is forward-biased, and will
not conduct when the voltage difference is below the cut-in
voltage, that is, when it is reverse-biased. Thus, the diode acts
as closed switch when it is forward-biased and as an open
switch when it is reverse-biased.

An advantage of using a diode switch in a switched-mode
power converter is its simplicity. However, diodes have a
fixed forward voltage drop that is independent of the amount
of current flowing in the diode. Typically, the voltage drop
across a diode is on the order of 0.5 to 1 volt, or more. The
electric power consumed by any device is the product of the
voltage drop across it times the current through it. Because of
the fixed forward voltage drop, high levels of power can be
dissipated in the form of heat in a switched-mode power
converter that uses ordinary diodes. Moreover, power losses
increase significantly with the amount of current that flows in

the diode. A special type of diode known as a Schottky diode has a smaller forward voltage drop than an ordinary diode, typically on the order of 0.15 to 0.45 volts. To achieve greater efficiency, Schottky diodes are commonly used as switches in switched-mode power converters.

Beginning with the invention of the transistor and later the integrated circuit, there has been and continues to be a trend to circuits with smaller and smaller features. In addition, there has been and continues to be a trend to circuits with higher and higher switching speeds. These trends are widely recognized. Within the field of power engineering, several related trends are recognized which concern the requirements of switched-mode power converters that supply power to these smaller and faster circuits. Specifically, switched-mode power converters must be made to fit within dimensions that are increasingly smaller, they must be able to supply voltages that are increasingly lower, and supply currents that are increasingly higher. For example, the typical required supply voltage has dropped from 5 volts to 3.3 volts, with devices in the near future expected to require only 1.5 volts. In addition, gigahertz switching speeds are now common and the current required in a circuit generally increases with frequency. Moreover, because many circuits today are battery powered so that devices incorporating them can be used with mobility, there is a need for switched-mode power converters that are ever more efficient. Yet another requirement of present electronic circuits stems from the power-saving "sleep mode" that many such circuits enter during periods of inactivity. A switched-mode power converter must be able to supply levels of energy for both normal and sleep modes. While Schottky diodes are more efficient as secondary switches than ordinary diodes, further improvements in efficiency and miniaturization would be desirable.

A synchronous rectifier is a type of switch that is significantly more efficient than a diode. In addition, a synchronous rectifier permits the use of smaller magnetic and electric storage elements. A synchronous rectifier is typically a MOSFET (metal-oxide-semiconductor field-effect transistor) and bypass diode embedded within the same silicon structure. In comparison to the 0.15 to 0.45 voltage drop of a Schottky diode, the voltage drop across a MOSFET during conduction is typically less than 0.1 volt. A MOSFET is a three terminal device in which a current will flow between a source terminal and a drain terminal if a control signal is applied to a gate terminal, provided of course that the source and drain are at different voltages. (The MOSFET is operated in cut-off and saturation modes, and accordingly when the control signal is applied it must be sufficient to place the MOSFET in saturation.) The MOSFET stops conducting and acts like an open circuit when the control signal is removed from the gate. Thus, the MOSFET acts as closed switch when there is no control signal on the gate and as an open switch when a control signal is applied.

MOSFET devices have properties that can create problems in certain switched-mode power converters or under certain conditions. Unlike a diode, a MOSFET is capable of conducting current in either direction, that is, from drain to source or from source to drain. If the load transitions from a state where it needs a lot of power to one where it needs much less power, it is possible that current can flow within the converter circuit in reverse of the intended direction. Reverse current flow can mean that energy is transferred from the load to the input source, reducing converter efficiency. Thus, synchronous rectifiers have generally only been used if the direction of current flow can be guaranteed. Another potential problem arises from the fact that the primary switch in a switched-mode converter is commonly a power MOSFET. If the primary

switch is turned on before the secondary switch has turned off, both MOSFETs will simultaneously conduct current, resulting in an undesirable "shoot-through" current. A shoot-through current generates large power losses and leads to rapid failure of the switching devices. For this reason, the control synchronous rectifiers must also be precisely regulated.

As mentioned, the use of a diode as a secondary switch in a switched-mode power converter has the advantage of simplicity: a diode does not require a control signal. When a synchronous rectifier replaces a diode, some method for providing a control signal is required. One method for providing a control signal is the "self-driven" method. In the self-driven method, the gate of the synchronous rectifier is directly coupled to a secondary winding of a transformer. However, in some circuit topologies, it may not be possible to implement the self-driven method. In addition, the self-driven method may not provide the required degree of precision. Self-driven topologies are typically not suited for applications where the input power or required load power fluctuates. Further, self-driven topologies are typically not suited for situations where two or more converters are coupled in parallel to supply a single load. In another method, the output voltage may be used as a feedback signal for a secondary switch control circuit. The use of output voltage suffers from the problem that it typically changes too slowly to provide rapid feedback concerning changes in the power requirements of the load. This slow response to fast current transients fails to protect switches and leads to devices failure. In yet another method, the output current may be used as a feedback signal for a secondary switch control circuit. While output current changes faster than output voltage, providing faster feedback than the voltage method, the use of the output current requires a current sensor. Thus, a disadvantage of use output current as a feedback signal is that an additional component is needed, a component which reduces efficiency by adding output impedance.

Accordingly, there is a need for a method and apparatus for providing a control signal for controlling a synchronous rectifier that does not suffer from the disadvantages of the known methods for providing a control signal.

SUMMARY

The present invention is directed to a switch mode power converter for supplying an output power to a load. The switch mode power converter includes, in a preferred embodiment, a switching device having a switching input, a switching output, and a control input for enabling or disabling the switching device from conducting current from the switching input to the switching output. The converter preferably also includes a network in which the switching device input, the switching device output, and the load are connected together to form a circuit. The converter preferably also includes a bias winding in the circuit for producing a bias voltage representative of the output power, and a control circuit. The control circuit is for (a) determining the rate of change of the bias voltage, (b) characterizing the rate of change, and (c) controlling the control input as a result of the characterization (b).

DRAWINGS

FIG. 1 illustrates a known switch mode power converter in a buck topology.

FIG. 2 illustrates a known switch mode power converter in a boost topology.

FIG. 3 illustrates a known switch mode power converter in a buck-boost topology.

FIGS. 4a-c illustrate a known switch mode power converter in a flyback topology.

FIGS. 5a-f illustrate waveforms of voltages and currents in the converter of FIG. 4 at different points in time.

FIGS. 6a-b illustrate a switch mode power converter in a flyback topology according to one embodiment of the present invention.

FIGS. 7a-g illustrate waveforms of voltages and currents in the converter of FIGS. 6a-b at different points in time.

FIG. 8 illustrates one embodiment of a control circuit of the present invention.

FIG. 9a illustrates a known switch mode power converter in a half-bridge topology.

FIG. 9b illustrates a switch mode power converter in a half-bridge topology according to one alternative embodiment of the present invention.

FIG. 10a illustrates a switch mode power converter in a two-transistor forward topology according to an alternative embodiment of the present invention.

FIG. 10b illustrates a timing diagram of the waveforms of voltages and currents of the converter of FIG. 10a at different points in time.

FIG. 10c illustrates the logic diagram of the converter of FIG. 10a.

FIG. 11a illustrates a switch mode power converter in a forward-flyback topology with a current-doubler, synchronize rectification, and active clamp topology according to an alternative embodiment of the present invention.

FIG. 11b illustrates a timing diagram of the waveforms of voltages and currents in the converter of FIG. 11a at different points in time.

FIG. 12a illustrates a switch mode power converter in half-bridge topology according to an alternative embodiment of the present invention.

FIG. 12b illustrates a timing diagram of the waveforms of voltages and currents in the converter of FIG. 12a at different points in time.

FIG. 12c illustrates a logic diagram of the converter of FIG. 12a.

FIG. 12d illustrates a timing diagram of the logic diagram of FIG. 12e at different points in time.

DESCRIPTION

The present invention is directed to a switch mode power converter for supplying an output power to a load. The switch mode power converter employs one or more synchronous rectifiers as secondary switching devices. In one preferred embodiment, the synchronous rectifiers may be placed in parallel with discrete diodes. During light load operation, the synchronous rectifiers are disabled and current is conducted in the body diodes of the synchronous rectifiers or in the parallel discrete diodes. In one preferred embodiment, the power converter also includes a bias winding for producing a bias voltage representative of the output power, and a control circuit. Light load conditions may be detected using the bias voltage. The control circuit is for (a) determining the rate of change of the bias voltage, (b) characterizing the rate of change, and (c) controlling the control input as a result of the characterization (b).

The present invention provides the benefits of using synchronous rectifiers as secondary switches during normal load conditions. In addition, the present invention allows for the use of either parallel diodes or body diodes during light load conditions. The present invention protects against reverse

current flow during light load conditions because the reverse current must be driven by a voltage that exceeds the diode cut-in voltage. Thus, in situations where two or more switch mode converters are connected in parallel to supply a single load and the output of one converter is at a slightly lower output voltage than the others, current will not flow into the lower voltage converter in reverse because the voltage difference would normally not be sufficient to overcome the diode cut-in voltage.

Flyback Converter

FIGS. 4a-c and 5a-f respectively illustrate an idealized switched-mode flyback DC-DC converter and idealized waveforms depicting voltages and currents within the circuit at different points in time. As shown in FIG. 4a, the flyback converter is coupled to an input DC power source, which supplies an input voltage V_{in} , and to an output load represented by a resistor R_L . The flyback converter includes a switch SW on a primary side, and a diode D and a capacitor C on a secondary side of the circuit.

The flyback converter includes a transformer T which magnetically couples the primary and secondary sides of the circuit. The transformer T has primary and secondary windings, L_1 and L_2 and a transformer core TC. When a current passes through one winding, a voltage is induced in the other winding. The polarity of the induced voltage depends on how the two windings are wound and a dot convention is conventionally employed to indicate the polarity of the induced voltage. According to the dot convention, if a current enters the dotted terminal of one winding, a positive voltage will be induced at the dotted terminal of the other winding.

The switch SW in the flyback converter may be open or closed. The time period when the switch SW is closed is referred to as T_{ON} or simply the "on" period and the time period when the switch is off is referred to as T_{OFF} or simply the "off" period. A switching time period T_S or "duty cycle" is defined as $T_S = T_{ON} + T_{OFF}$. During the on period, energy is stored in the transformer T. During the off period, the stored energy is transferred to the secondary side of the circuit. A current I_o flows in the load R_L during both the on and off periods. During the on period, energy that is stored in the capacitor C supports the current I_o .

FIG. 4b illustrates how the flyback converter circuit effectively looks during an on period. A short circuit has been substituted in the figure for the switch SW because the switch is closed during the on period. When the switch SW is closed, a current I_{pri} enters the dotted terminal of the primary winding L_1 . The current I_{pri} induces a voltage in the secondary winding which, according to the dot convention, is positive at its dotted terminal and as a result, the diode D is reverse-biased. The diode D has been replaced with an open circuit in FIG. 4b because it is reverse-biased. During the on period, the current I_{pri} flows in the primary winding L_1 storing energy in the transformer T. Referring to FIGS. 5a, 5b, and 5c, it can be seen that during the on periods, the voltage V_{SW} across the switch is zero, the voltage V_{pri} across the primary winding is equal to the input voltage V_{in} , and the current I_{pri} in the primary winding ramps up with time. Since the diode D is reverse-biased during the on period, the current I_{sec} in the secondary winding L_2 is zero, as shown in FIG. 5f.

FIG. 4c illustrates how the flyback converter circuit effectively looks during an off period. An open circuit has been substituted in the figure for the switch SW because the switch is open during the off period. After the switch is opened, the polarity of the voltage V_{pri} across the primary winding L_1 reverses which in turn causes the voltage V_{sec} across the secondary winding L_2 to reverse its polarity. The reversal of

polarity in the secondary winding L_2 causes a current I_{sec} to flow in the secondary winding. In addition, the diode D is forward-biased during the off period as a result of the reversal of polarity in the secondary winding L_2 . For this reason, the diode D has been replaced with a short circuit in FIG. 4c. Referring to FIGS. 5a, 5b, and 5c, it can be seen that during the off periods, the voltage V_{SW} across the switch is positive, the voltage V_{pri} across the primary winding is negative, and the current I_{pri} in the primary winding L_1 is zero. Because the diode D is forward-biased during the off period, the current I_{sec} in the secondary winding L_2 ramps down with time, as shown in FIG. 5f.

Synchronous Rectification-Flyback Topology

One preferred embodiment of the present invention is shown in FIGS. 6a-b. A flyback converter (the "SR flyback converter") which employs a synchronous rectifier is illustrated in FIGS. 6a-b and waveforms depicting voltages and currents in the circuit at different points in time are shown in FIGS. 7a-g. As shown in FIG. 6a, the SR flyback converter is coupled to an input DC power source, which supplies an input voltage V_{in} , and to an output load represented by a resistor R_L . The SR flyback converter includes a switch SW on a primary side, and a synchronous rectifier SR, a Schottky diode D, and a capacitor C on a secondary side of the circuit. In addition, the SR flyback converter includes a control circuit CC for generating a control signal V_{C-SW} for the switch SW and a control signal V_{C-SR} for the synchronous rectifier SR.

As shown in FIGS. 6a-b, the SR flyback converter includes a transformer T which magnetically couples the primary and secondary sides of the circuit. The transformer T has primary and secondary windings, L_1 and L_2 , and a transformer core TC. The dots shown adjacent to one terminal of the primary and secondary windings, L_1 and L_2 are placed according to the dot convention. The dots for the windings are placed in the same position as those for the flyback converter of FIGS. 4a-c. The SR flyback converter additionally includes a bias winding, L_B . The bias winding L_B is coupled to the control circuit CC so that it can provide it with a bias voltage V_B and a bias current.

As with the flyback converter of FIGS. 4a-c, the switch SW in the SR flyback converter may be open or closed. Similarly, the SR flyback converter has a "duty cycle" that is defined by $T_S = T_{ON} + T_{OFF}$. Moreover, the SR flyback converter operates similarly to the flyback converter shown in FIGS. 4a-c. During the on period of the SR flyback converter, energy is stored in the transformer T and during the off period, the stored energy is transferred to the secondary side of the circuit.

Unlike the flyback converter of FIGS. 4a-c, the SR flyback converter includes the synchronous rectifier SR and has two modes of operation. In "normal" mode, the synchronous rectifier SR is enabled and in the "light load" mode, it is disabled. Under conditions when the load R_L is deemed to be normal, the synchronous rectifier SR performs a switching function similar to the diode D illustrated in FIGS. 4b-c. However, under conditions when the load R_L is deemed to be "light," the synchronous rectifier SR is disabled and the switching function is performed by the diode D. FIG. 6b illustrates how the SR flyback converter circuit effectively looks under light load conditions. In FIG. 6b, because the synchronous rectifier is disabled during the light load period, a short circuit has been substituted for the synchronous rectifier SR.

Referring to FIGS. 7a-b, and 7d-g, it can be seen that during the on periods, the voltage V_{SW} across the switch is zero, the control signal V_{C-SR} for the switch SW is high and the voltage V_{sec} across the secondary winding L_2 is negative. Because the voltage V_{sec} is negative, the diode D is reverse-

biased. In addition, the control signal V_{C-SR} for the synchronous rectifier SR is low, indicating that it is turned off. Because the diode D is reverse-biased and the synchronous rectifier SR is off, the currents I_{D1} and I_{SR} in the diode D and the synchronous rectifier SR, respectively, are zero.

FIGS. 7b, 7d, and 7e show arrows that will be understood by one skilled in the art, but which may require explanation for others. The arrows illustrate cause and effect relationships. The solid circle at the tail of an arrow indicates a signal transition or level that causes some action and the point of the arrow indicates the action caused. For instance, the transition of V_{S-SW} (see FIG. 7b) from a low to a high at the start of on periods 1 and 2 causes the signal V_{C-SR} to transition from a high to a low at the times indicated in FIG. 7e.

The SR flyback converter operates in one of its two modes of operation during the off period. Referring to FIGS. 7a-b, it can be seen that the voltage V_{SW} across the switch is positive and the control signal V_{C-SW} for the switch SW is low during the off periods. The mode of operation for normal load conditions is shown for off periods 1 and 2, and the mode for light load conditions is shown for off period 3. Referring to FIG. 7e, it can be seen that, during the normal load off periods 1 and 2, the control signal V_{C-SR} for the synchronous rectifier SR is high, indicating that the SR is functioning as a closed switch. Referring to FIG. 7f, it can be seen that the current I_{SR} flowing in the synchronous rectifier ramps down with time during off periods 1 and 2. Referring now to FIG. 7e, it can be seen that, during the light load off period 3, the control signal V_{C-SR} for the synchronous rectifier SR is low, indicating that it is functioning as an open switch. Referring to FIG. 7g, it can be seen that current I_{D1} in the diode ramps down with time during the light load off period 3. As FIGS. 7f-g show, current flows in either the synchronous rectifier SR or the diode during the off time.

FIG. 7d shows the voltage V_{sec} across the secondary winding L_2 . A reference threshold voltage V_{TH} is also shown. In contrast to the idealized waveform of FIG. 5d which shows the voltage V_{sec} across the secondary winding L_2 becoming instantly positive at the end of the on period, the voltage V_{sec} that is shown in FIG. 7d illustrates a more realistic view of the transition that occurs at the end of the on period. The voltage does not rise instantly; instead, it rises with a delay that defines an upward sloping line. (The voltage V_{sec} shown is somewhat exaggerated for purposes of clarity of illustration.) At the end of the on period, a V_{DELAY} signal goes high, as shown in FIG. 7c. After a delay period, the V_{DELAY} signal goes low. During the delay period, the voltage V_{sec} is compared with the threshold voltage V_{TH} , as shown in FIG. 7e. The control signal V_{C-SR} for the synchronous rectifier SR is enabled if the voltage V_{sec} becomes greater than the threshold voltage V_{TH} during the delay period, otherwise, the control signal V_{C-SR} is disabled.

FIG. 8 shows one embodiment of a control circuit CC, which includes a comparator 100, an RS latch 102, a delay block 104, an inverter 106, and AND gates 108 and 110. The control signal V_{C-SW} is coupled to the inputs of the RS latch 102, the delay block 104, and the inverter 106. The voltage V_{sec} is coupled to the non-inverting input of the comparator 100 and the threshold voltage V_{TH} is coupled to inverting input of the comparator 100. The output of AND gate 110 is the control signal V_{C-SR} for the synchronous rectifier SR.

In operation of the control circuit CC shown in FIG. 8, the control signal V_{C-SW} is low during an off period. The control signal V_{C-SW} causes a low signal to be placed on the R input of RS latch 102. In addition, it causes a delay period to begin at the start of the off period. During the delay period, the delay block causes a high signal to be placed on one input of the

AND gate **108**. An inverted version of V_{C-SW} (a high signal) is placed on the other input of the AND gate **108** during the off period, as a result of the inversion performed by inverter **106**. Thus, during the delay period, the output of the AND gate **108** is high, which enables the comparator **100**.

When the delay period ends, the comparator **100** is disabled. At the start of the off period, the voltage V_{sec} across the secondary winding L_2 is negative, beginning its rise to a positive voltage. Thus, the output of the comparator **100** is low at the start of the off period and the output of the comparator **100** will go high when the voltage V_{sec} exceeds the threshold voltage V_{TH} . If it does go high during the delay period, the RS latch **102** will enter a set state, latching a high signal on its output and the input to the AND gate **110**. Because the other input on the AND is high as a result of the inversion of signal V_{C-SW} , the output of AND gate **110** will also go high during the off period. Since this output is control signal V_{C-SR} for the synchronous rectifier SR, it is turned on during the off period.

If, on the other hand, the voltage V_{sec} does not exceed the threshold voltage V_{TH} during the delay period, the comparator **100** will be disabled while its output is low. As a result, the RS latch **102** will remain in a latched state, latching a low signal on its output and the input to the AND gate **110**. Since, the AND gate's output control signal V_{C-SR} is low, the synchronous rectifier SR will be turned off during the off period.

Use of the Voltage in the Bias Winding

In the description of the operation of the SR flyback converter illustrated in FIGS. **6a-b**, it was shown how the voltage V_{sec} across the secondary winding L_2 is compared with the threshold voltage V_{TH} during a delay period to determine whether the control signal V_{C-SR} should be enabled or disabled. The use of voltage V_{sec} illustrates but one preferred voltage that may be compared with the threshold voltage V_{TH} according to the present invention. In another preferred embodiment of the present invention, the bias voltage V_B , that is provided by the bias winding L_B shown in FIGS. **6a-b**, may be compared with the threshold voltage V_{TH} .

Transformers generally have leakage inductance, usually modeled as an additional inductance L_d in series with the secondary winding L_2 . Any inductive element, such as the leakage inductance L_d will resist and hence delay any change in the current flowing through the element. As previously described, the polarities of the voltages across the primary winding L_1 and the secondary winding L_2 reverse when the primary switch is opened. However, these polarity changes do not occur precisely simultaneously. The change in polarity occurs first in the primary winding L_1 , with the change in polarity in the secondary winding L_2 occurring at a slower rate than in the primary. The rate of change of the polarity in the secondary winding L_2 depends on the leakage inductance L_d as well as the amplitude of the output current and other factors.

It is believed that the bias voltage V_B provided by the bias winding L_B reflects a polarity change with less delay from that in the primary winding L_1 , than the voltage V_{sec} across the secondary winding L_2 . This property of the bias voltage V_B is believed to be due to the fact that the bias winding L_B carries a current that is low in amplitude in comparison to the output current. The bias winding L_B is typically employed to provide electric power to the control circuitry of the power converter, circuitry which requires only a modest amount of current. For this reason, it is believed that the bias voltage bias V_B may be advantageously compared with the threshold voltage V_{TH} to provide an earlier indication of when the polarity across the primary winding L_1 has changed. As mentioned, methods for

controlling secondary synchronous rectifier switches that rely on sensing output current may not drive the synchronous rectifiers with adequate precision and they require a current sensor. Precision may be lacking because the output current can vary greatly during the delay period. In contrast, use of the bias voltage bias V_B provides an earlier indication of the polarity change in the primary winding L_1 allowing the synchronous rectifiers to be driven more precisely. In addition, the use of the bias voltage V_B provides the advantage that it does not require an additional current sensor component, as it employs an existing component of the power converter, namely the bias winding L_B .

It should be understood that the present invention may be practiced with a bias winding L_B located on either the primary or secondary side of the transformer. In addition, the bias winding L_B may be additionally employed to supply power to a control or other circuit, or the bias winding L_B may be employed solely for the purpose of providing a bias voltage V_B for comparison with the threshold voltage V_{TH} . In addition, the bias winding L_B may be all or part of either the primary or secondary windings L_1 , L_2 of the transformer. Further, the bias winding L_B may be provided in a topology that does not include a transformer, such as those shown in FIGS. **1-3**.

Control of Synchronous Rectifiers in Other Topologies

The method and apparatus of the present in invention for controlling a synchronous rectifier used as secondary switch has been described herein in the context of one preferred embodiment, namely the SR flyback converter. It should be understood, however, that the present invention was described in the context of the SR flyback converter for the purpose of clarity, that is, the features of the invention may be more readily understood in the context of a topology that does not include a large number of components and signals. But it should be understood that the present invention is not limited to the SR flyback converter. As will be appreciated by one skilled in the art, the present invention may be advantageously employed in any topology which uses synchronous rectifiers. Specifically, the present invention may be employed in topologies that include a transformer and in those that do not. Further, the present invention may be employed in those topologies that have been previously described or referred to herein as well as in other topologies known in the art. FIGS. **10a-b**, **12a-b**, and **13a-b**, which are briefly described below, provide additional illustrations of topologies in which the present invention may be advantageously employed.

FIG. **10a** illustrates a switch-mode power converter that is based on a known two-transistor forward topology, according to one alternative preferred embodiment of the present invention. In known forward switch-mode power converters, the drive signals for the secondary switches such as $V_C(SR1)$ and $V_C(SR2)$ are determined by the drive signals for the primary switches and the output current. A disadvantage of the known half-bridge converter is that the synchronous rectifiers may be turned on before the voltage changes in the secondary winding. In addition, the current sensor is an extra component, a component that introduces an impedance in the output, an impedance which causes a reduction in efficiency.

Referring to FIG. **10a**, the parallel diodes shown on the secondary side and coupled to the circuit by dashed lines may be either body diodes of the synchronous rectifiers SR1 and SR2 or additional discrete diodes. The half-bridge converter includes a bias winding N_f from which a bias voltage V_f is derived. A control circuit, which is not shown in FIG. **10a**, generates two drive signals, $V_C(SR1)$ and $V_C(SR2)$, that are

11

shown and used to control synchronous rectifiers SR1 and SR2. This control circuit functions in a similar manner to the control circuit previously described for the SR flyback converter, however, it is not identical to the previously described control circuit. The operation of this control circuit can be best understood by reference to FIG. 10b.

As can be seen in FIG. 10b, the bias voltage V_f is compared with threshold voltages V_{TH1} and V_{TH2} during first and second delay periods δ . From the arrows having their tails on the transitions of either the primary control voltage Vc(S1) or the bias voltage V_f and their heads pointing to transitions of Vc(SR1) and Vc(SR2), it can be seen that when the bias voltage V_f transitions past the threshold voltage during a delay period δ , the effect is a change in the level of the control signals for the synchronous rectifiers Vc(SR1) and Vc(SR2). The signal Vc(SR2) is driven low when Vc(S1) goes high and is driven high when V_f exceeds the threshold voltage during the delay period δ . The signal Vc(SR1) is driven high when V_f becomes more negative than the threshold voltage during the delay period δ and is driven low when V_f becomes more positive than the threshold voltage during the delay period δ . The foregoing transitions correspond to periods when the load, represented by R_o , is considered heavy. During periods when the load is considered light, it can be seen from an arrow L having its tail on the dotted line adjacent to the rising edge of a bias voltage V_f transition and its head on the transition of the disable signal to "disable on" that the control signals Vc(SR1) and Vc(SR2) are made inactive following this transition. In other words, when the delay in the rise in the bias voltage V_f is such that it does not exceed the threshold voltage V_{TH1} during the delay period δ , the synchronous rectifiers SR1 and SR2 are disabled and currents are conducted instead through the parallel diodes on the secondary side which are coupled to the circuit by dashed lines.

In FIG. 10c is presented the logic diagram associated with the timing diagram of FIG. 10b. In FIG. 10c the Vc(S1) 110 is applied to an Inverter 170 and after that to an AND gate 190. If the enable signal 750 is high then the Vc(SR2) 104 is the inverted signal of Vc(S1) though the rising edge will occur only during the time interval δ after the falling edge of 110, when Vf 106 is higher than Vth1 114. If this condition does not occur during the time interval δ the enable will have a low logic level and the output of 190 will be low as well. The gate 176 enables the comparator 180 during the time interval δ .

During the time interval δ after the rising edge of 110, and during the time interval δ after the falling edge of 110, the comparator 182 is activated. If Vf 106 is lower than Vth2 116, then the Q output of 186 will be high and the output of gate 188 will be high as well. This controls the rising edge of Vc(SR1) 102.

The falling edge of 102 will occur during the time interval δ after the falling edge of Vc(S1). During that time 182 will be activated again. If Vf 106 is higher than Vth2 116 during the time interval δ then the output Q of 186 will go logic low and the output of 188 will go low as well. In the event wherein this condition does not occur during the time interval δ then 186 will be reset and the output Q of 186 will go logic low and the output of 188 will go low. The time interval δ can be different after the falling edge and rising edge of the primary control switch.

FIG. 11a illustrates a switch mode power converter in a topology known as forward-flyback with current-doubler, synchronous rectification, and active clamp according to an alternative embodiment of the present invention. FIG. 11a is a representative example of an asymmetrical topology. In asymmetrical topologies, one secondary switch conducts during the forward transfer of power and one secondary

12

switch conducts during the flyback transfer. The method and apparatus of the present invention may be advantageously employed in controlling the secondary switch that conducts during the flyback transfer.

Referring to FIG. 11a, the parallel diodes shown on the secondary side and coupled to the circuit by dashed lines may be either body diodes of the synchronous rectifiers SR1 and SR2 or additional discrete diodes. The two-transistor forward converter includes a bias winding N_f from which a bias voltage V_f is derived. A control circuit, which is not shown in FIG. 10a, generates two drive signals, Vc(SR1) and Vc(SR2), that are shown and used to control synchronous rectifiers SR1 and SR2. This control circuit functions in a similar manner to the control circuit previously described for the SR flyback converter, however, it is not identical to the previously described control circuit. The operation of this control circuit can be best understood by reference to FIG. 11b.

FIG. 11b shows a timing diagram of the waveforms of voltages and currents in the circuit of FIG. 11a at different points in time. As can be seen in FIG. 11, the bias voltage V_f is compared with threshold voltages V_{TH1} and V_{TH2} during a first and second delay periods δ . From the arrows having their tails on transitions of either the primary control voltage Vc(S1) or the bias voltage V_f and their heads pointing to transitions of Vc(SR1) and Vc(SR2), it can be seen that when the bias voltage V_f transitions past the threshold voltage during a delay periods δ , the effect is a change in the level of the control signals for the synchronous rectifiers Vc(SR1) and Vc(SR2). The signal Vc(SR2) is driven low when Vc(S1) goes high and is driven high when V_f exceeds the threshold voltage during the delay periods δ . The signal Vc(SR1) is driven high when V_f becomes more negative than the threshold voltage during the delay period δ and is driven low when V_f becomes more positive than the threshold voltage during the delay period δ . The foregoing transitions correspond to periods when the load, represented by R_o , is considered heavy. During periods when the load is considered light, it can be seen from an arrow L having its tail on the rising edge of a bias voltage V_f transition and having two heads, one on the falling edge of Vc(SR1) and the second head on the transition of the disable signal to "disable on" that the control signals Vc(SR1) and Vc(SR2) are made inactive following this transition. In other words, when the delay in the rise in the bias voltage V_f is such that it does not exceed the threshold voltage V_{TH2} during the delay period δ , the synchronous rectifiers SR1 and SR2 are disabled and currents are conducted instead through the parallel diodes on the secondary side which are coupled to the circuit by dashed lines.

FIG. 12a illustrates a switch mode power converter in a half-bridge topology, according to yet another alternative embodiment of the present invention. FIG. 12a is a representative example of a symmetrical topology. FIG. 12b shows a timing diagram of the waveforms of voltages and currents in the circuit at different points in time.

It will be recalled that in symmetrical topologies both secondary switches conduct during the flyback transfer. In addition, both secondary switches transfer energy during the forward transfer. At the end of the forward cycle when one of the primary switches turns off, there is a voltage rise across the primary switches, a voltage rise which is a function of the loading conditions. As the load increases, the slope of the voltage rise across the primary switches also increases.

Referring to FIG. 12a, the parallel diodes shown on the secondary side and coupled to the circuit by dashed lines may be either body diodes of the synchronous rectifiers SR1 and SR2 or additional discrete diodes. The half-bridge converter includes bias windings L_{B1} and L_{B2} from which bias voltages

V_{f1} and V_{f2} are derived. A control circuit, which is not shown in FIG. 10a, generates two drive signals, Vc(SR1) and Vc(SR2), that are shown and used to control synchronous rectifiers SR1 and SR2. This control circuit functions in a similar manner to the control circuit previously described for the SR flyback converter, however, it is not identical to the previously described control circuit. The operation of this control circuit can be best understood by reference to FIG. 12b.

As can be seen in FIG. 12b, the bias voltages V_{f1} and V_{f2} are compared with threshold voltages V_{TH1} and V_{TH2} during a delay period δ . From the arrows having their tails on the transitions of either the primary control voltages Vc(S1) or Vc(S2), or the bias voltages V_{f1} and V_{f2} and their heads pointing to transitions of Vc(SR1) and Vc(SR2), it can be seen that when the bias voltages V_{f1} and V_{f2} transition past the threshold voltages during a delay period δ , the effect is a change in the level of the control signals for the synchronous rectifiers Vc(SR1) and Vc(SR2). The signal Vc(SR2) is driven low when Vc(S1) goes high and is driven high when V_{f2} exceeds the threshold voltage during the delay period δ . The signal Vc(SR1) is driven low when Vc(S2) goes high and is driven high when V_{f1} becomes more positive than the threshold voltage during the delay period δ . The foregoing transitions correspond to periods when the load, represented by R_o , is considered heavy. During periods when the load is considered light, it can be seen from an arrow L having its tail on the dotted line adjacent to the rising edge of a bias voltage V_{f2} transition and its head on the transition of the disable signal to “disable (SR2) and disable (SR1)” that the control signals Vc(SR1) and Vc(SR2) are made inactive following this transition. In other words, when the delay in the rise in the bias voltage V_{f1} is such that it does not exceed the threshold voltage V_{TH1} during the delay period δ , the synchronous rectifiers SR1 and SR2 are disabled and currents are conducted instead through the parallel diodes on the secondary side which are coupled to the circuit by dashed lines.

The present invention may be advantageously employed in controlling both of the secondary switches during the flyback transfer. It will be noted that the bias voltage may be sensed in either the high current secondary winding or in the lower current windings shown on the primary side. FIG. 12b shows a timing diagram of the waveforms of voltages and currents in the circuit at different points in time.

In FIG. 12C is presented the logic diagram which controls the Synchronized Rectifiers according with the time diagram of FIG. 12B. The logic diagram of FIG. 12C is for Vc(SR2) but it is identical for the Vc(SR1) with the difference that the input signal in A 514 will be Vc(S2) and V_{f1} will replace the V_{f2} and the Vth2442 will be replaced by Vth1.

The key waveforms of logic diagram of FIG. 12C is presented in FIG. 12D. On line 500 is presented the input signal A 514, on line 502 is presented the signal after the delay cell 454. The output signal 518 of the gate 458 is connected to the reset input of 462. The output signal 520 of the gate 456 is enabling the comparator 464 during the time interval δ 416. If the output of 464 is high during 416 then Q output of 462 goes high and Vc(SR2) goes high as well. In the event wherein the output of 464 is not high during 416, then the output Q of 462 is maintained low and the Vc(SR2) skips the rising edge during this cycle.

FIG. 9a shows a known switch-mode power converter in a half-bridge topology. The control signals Vc (SR1) and Vc (SR2) for the synchronous rectifiers SR1 and SR2 are determined by the control signals for the primary switches Vc (S1) and Vc (S2). The known power converter requires a current sensor shown on the line to the Load R_o . A comparator

compares the sensed in current to a reference current and enables or disables the control signals based on this comparison.

FIG. 9b shows a switch-mode power converter in a half-bridge topology according to the present invention. The control signals for the secondary rectifiers SR1 and SR2 are determined by the control signals for the primary switches Vc (S1) and Vc (S2), and by the rate of change of the voltage V_B in the bias winding. As previously described, under conditions when the load R_o is heavy or normal the rate of use of the voltage is such that the control signals for the synchronous rectifiers are enabled. Under conditions of light load R_o , the synchronous rectifiers are disabled.

The terms and expressions that have been employed in the foregoing specification are used as terms of description and not of limitation, and are not intended to exclude equivalents of the features shown and described or portions of them. The scope of the invention is defined and limited only by the claims that follow.

The invention claimed is:

1. A power converter for supplying an output power to a load, comprising:

- a switching device having a switching input, a switching output, and a control input for enabling or disabling said switching device from conducting current from said switching input to said switching output; and
- a network wherein said switching device input, said switching device output, and the load are connected together in a circuit;

a bias winding in said circuit for producing a bias voltage representative of the output power; and

a control circuit for (a) determining the rate of change of said bias voltage, (b) characterizing said rate of change, and (c) controlling said control input as a result of the characterization (b);

the control circuit being responsive to the characterized bias voltage rate of change to control the switching device and

- (i) effect a heavy load mode of operation of the power converter when the rate of change is above a predetermined level and
- (ii) effect a light load mode of operation of operation of the power converter when the rate of change is below the predetermined level.

2. The power converter of claim 1, further comprising a power input portion and a power output portion for providing said output power, wherein said circuit is in said power output portion.

3. The power converter of claim 2, further comprising a connecting portion for coupling said power input portion to said power output portion, wherein said connecting portion includes an inductor as part of said power output portion, wherein said bias winding is coupled in series with said inductor.

4. The power converter of claim 3, wherein said connecting portion includes a transformer having a primary winding as part of said power input portion and a secondary winding which includes said inductor.

5. The power converter of claim 1, wherein said control circuit is adapted so that the determination (a) includes comparing said bias voltage at a selected time relative to a selected starting value of said bias voltage, and so that the characterization (b) includes comparing the change in said bias voltage in (a) to a reference.

6. The power converter of claim 2, wherein said control circuit is adapted so that the determination (a) includes comparing said bias voltage at a selected time relative to a selected

15

starting value of said bias voltage, and so that the characterization (b) includes comparing the change in said bias voltage in (a) to a reference.

7. The power converter of claim 3, wherein said control circuit is adapted so that the determination (a) includes comparing said bias voltage at a selected time relative to a selected starting value of said bias voltage, and so that the characterization (b) includes comparing the change in said bias voltage in (a) to a reference.

8. The power converter of claim 4, wherein said control circuit is adapted so that the determination (a) includes comparing said bias voltage at a selected time relative to a selected starting value of said bias voltage, and so that the characterization (b) includes comparing the change in said bias voltage in (a) to a reference.

9. The power converter of claim 5, wherein said characterization (b) includes determining whether the rate of change is either high or low compared to said reference.

10. The power converter of claim 6, wherein said characterization (b) includes determining whether the rate of change is either high or low compared to said reference.

11. The power converter of claim 7, wherein said characterization (b) includes determining whether the rate of change is either high or low compared to said reference.

12. The power converter of claim 8, wherein said characterization (b) includes determining whether the rate of change is either high or low compared to said reference.

13. In a power converter, a method for supplying an output power to a load, comprising the steps of:

providing a power input portion;

providing a power output portion comprising a switching device having a switching input, a switching output, and a control input for enabling or disabling said switching device from conducting current from said switching input to said switching output, and a network wherein said switching device input, said switching device output, and the load are connected together in a circuit;

providing a bias voltage representative of the output power; determining the rate of change of said bias voltage; characterizing said rate of change; and

controlling said control input as a result of said step of characterizing to control the switching device and

(i) effect a heavy load mode of operation of the power converter when the rate of change is above a predetermined level and

(ii) effect a light load mode of operation of the power converter when the rate of change is below the predetermined level.

14. The method of claim 13, wherein said step of determining includes comparing said bias voltage at a selected time relative to a selected starting value of said bias voltage, and wherein said step of characterizing includes comparing the change in said bias voltage in said step of determining to a reference.

15. The method of claim 14, wherein said step of characterizing includes determining whether the rate of change is either high or low compared to said reference.

16. A power converter for supplying an output power to a load, comprising:

a magnetic storage element;

a switch on a primary side of the magnetic storage element; a synchronous rectifier on a secondary side of the magnetic storage element having a switching input, a switching output and a control input for enabling or disabling said synchronous rectifier from conducting current from said switching input to said switching output;

16

a network wherein said switching input, said switching output and the load are connected together in a circuit; a bias winding in said circuit for producing a bias voltage representative of the output power; and

a control circuit operatively connected to:

- (a) determine the rate of change of said bias voltage,
- (b) characterize said rate of change as indicative of a light or heavy load on the power converter, and
- (c) control said control input as a result of the characterization (b).

17. The power converter of claim 16, further comprising a power input portion and a power output portion for providing said output power, wherein said circuit is in said power output portion.

18. The power converter of claim 17, further comprising a connecting portion for coupling said power input portion to said power output portion, wherein said connecting portion includes an inductor as part of said power output portion, wherein said bias winding is coupled in series with said inductor.

19. The power converter of claim 18, wherein said connecting portion includes a transformer having a primary winding as part of said power input portion and a secondary winding which includes said inductor.

20. The power converter of claim 16, wherein said control circuit is adapted so that the determination (a) includes comparing said bias voltage at a selected time relative to a selected starting value of said bias voltage, and so that the characterization (b) includes comparing the change in said bias voltage in (a) to a reference.

21. The power converter of claim 20, wherein said characterization (b) includes determining whether the rate of change is either high or low compared to said reference.

22. In a power converter, a method for supplying an output power to a load, comprising the steps of:

providing a magnetic storage element;

providing a power input portion comprising a switch;

providing a power output portion comprising a synchronous rectifier having a switching input, a switching output and a control input for enabling or disabling said synchronous rectifier from conducting current from said switching input to said switching output, and a network wherein said switching input, said switching output and the load are connected together to a circuit;

providing a bias voltage representative of the output power; characterized in that said method further comprises the steps of:

determining the rate of change of said bias voltage; characterizing said rate of change as indicative of a light or a heavy load on the power converter; and

controlling said control input as a result of said step of characterizing.

23. The method of claim 22, wherein said step of determining includes comparing said bias voltage at a selected time relative to a selected starting value of said bias voltage, and wherein said step of characterizing includes comparing the change in said bias voltage in said step of determining to a reference.

24. The method of claim 23, wherein said step of characterizing includes determining whether the rate of change is either high or low compared to said reference.

25. The power converter of claim 1, wherein the control circuit is responsive to rate of change of the bias voltage to control said control input to:

open the switching device and prevent conduction of current therethrough to the load in a first, light load mode of operation of the power converter; and

17

close the switching device and cause conduction of current therethrough to the load in a second, normal load mode of operation.

26. The method of claim 13, wherein controlling said control input comprises, in response to the rate of change of the bias voltage comprises:

opening the switching device and preventing conduction of current therethrough to the load in a first, light load mode of operation of the power converter; and

closing the switching device and causing conduction of current therethrough to the load in a second, normal load mode of operation.

27. The power converter of claim 16, wherein the control circuit is responsive to rate of change of the bias voltage to control said control input to:

disable the synchronous rectifier and prevent conduction of current therethrough to the load in a first, light load mode of operation of the power converter; and

enable the synchronous rectifier and cause conduction of current therethrough to the load in a second, normal load mode of operation.

28. The method of claim 22, wherein controlling said control input comprises, in response to the rate of change of the bias voltage comprises:

disabling the synchronous rectifier and preventing conduction of current therethrough to the load in a first, light load mode of operation of the power converter; and

enabling the synchronous rectifier and causing conduction of current therethrough to the load in a second, normal load mode of operation.

29. The power converter according to claim 1, wherein the control circuit enables the switching device when the load is heavy and disables the switching device when the load is light.

18

30. The power converter according to claim 29, further comprising a diode in said circuit to serve as a secondary switch in a power output portion of the power converter when the switching device is disabled in the light load mode of operation of the power converter.

31. The power converter according to claim 30, wherein the switch device is a semiconductor switching device in parallel with the synchronous rectifier.

32. The power converter according to claim 31, wherein the diode is a discrete component distinct from the semiconductor switching device.

33. The power converter according to claim 31, wherein the diode is a body diode of the semiconductor switching device.

34. The method of claim 13, further comprising enabling the switching device when the load is heavy and disabling the switching device when the load is light.

35. The method according to claim 34, further comprising providing a diode as a secondary switch in the power output portion of the power converter when the switching device is disabled in the light load mode of operation of the power converter.

36. The method according to claim 35, further comprising providing a semiconductor switching device as the switching device of the power output portion of the power converter in parallel with the diode.

37. The method according to claim 36, wherein providing a diode comprises providing a diode that is a discrete component distinct from the semiconductor switching device.

38. The method according to claim 36, wherein providing a diode comprises providing a body diode of the semiconductor switching device.

* * * * *